

## KEENCUT EVOLUTION 3 TM - FreeHand



### MATERIALS CUT:

#### *Semi-rigid materials*

- Corrugated cardboard  $\leq 6\text{mm}$  (1/4")
- PVC foamboard  $\leq 6\text{mm}$  (1/4")
- Corrugated plastic  $\leq 6\text{mm}$  (1/4")
- Foam centred board  $\leq 6\text{mm}$  (1/4")

#### *Rigid materials*

- Cast acrylic / Plexiglas  $\leq 3\text{mm}$  (3/32") scoring only

#### *Flexible materials*

- Banners
- Pop-ups
- Magnetic sheets
- Self-adhesive vinyls



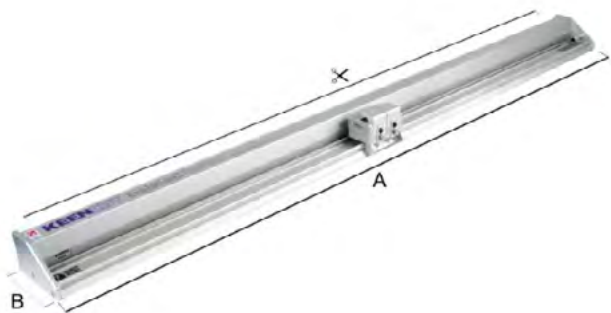

DIMENSIONS	E3FH110	E3FH160	E3FH210
Cut length cm	110 (44)	160 (64)	210 (84)
A cm	142 (56)	192 (75.5)	242 (95)
B cm	15.5 (6)	15.5 (6)	15.5 (6)
Packed Weight KG	22 (48.5)	28 (62)	34 (75)
Packed Dimensions cm	157 x 35 x 17 (61 x 14 x 7)	204 x 35 x 17 (80 x 14 x 7)	254 x 35 x 17 (100 x 14 x 7)

DIMENSIONS	E3FH260	E3FH310
Cut length cm	260 (104)	310 (124)
A cm	292 (115)	342 (134.5)
B cm	15.5 (6)	15.5 (6)
Packed Weight KG	40 (88)	46 (101)
Packed Dimensions cm	304 x 35 x 17 (120 x 14 x 7)	354 x 35 x 17 (140 x 14 x 7)

## Features

- Cuts up to 4 times faster than cutting by hand
- Simple, precision alignment reduces waste and saves time
- Clean quality cuts with no dust or debris
- Single person operation
- Cutting, scoring, creasing and fabric cutting
- Safety by design
- 5 year guarantee

## Guaranteed accuracy

The Evolution3 es el cortador más preciso de su tipo en el mercado y está garantizado para cortar dentro de 0.2mm (0.008 pulgadas) de una línea recta a lo largo de todo el corte. La precisión ultra precisa incorporada, combinada con la alineación perfecta posible utilizando la tira de línea de visión, significa que cada panel unido a tope se unirá sin problemas. Esta precisión ultra precisa te ahorrará tiempo y dinero al reducir el desperdicio y los errores.



The self-adjusting track roller system fitted to the QuikSwap tool heads provides a strong and smooth movement up and down the length of the cutter bar, with zero sideways movement to ensure a perfect straight line. This, coupled with rigid blade clamping gives perfect blade control and spot-on accuracy, so less wastage and mistakes. On the FreeHand, the underside of the cutter bar has two silicone strips that will grip to the material surface preventing any chance of it slipping.

## Total stability





## Simple to use

The ease of use makes it possible for even first time users to cut confidently and accurately with the Evolution3 FreeHand. The sightline strip guides you to achieve perfect accuracy and the heavy base and solid structure create a stable cutting platform.

## Heavy duty reliability

The entire Evolution3 range has been built to last, using high quality materials and well tested engineering principles. The cutting head bearing system and clamping are tough enough to keep perfect blade control, even with the most difficult of materials. Keencut makes the majority of components on its precision CNC machines, keeping tolerances and quality under constant control, assuring exceptional accuracy and total reliability.



## QuikSwap Double Graphik tool head



The Evolution3 Double Graphik tool head comes as standard and has two individual blade holders for two-way cutting. The blades are stronger and more stable than regular blades making the Double Graphik tool ideal for vinyl, banner, cardboard, PVC foamboard up to 13mm (1/2"), foam-centred board, corrugated plastic, paper, pop-up and roll-up materials.

## Optional Evolution3 tool heads

Evolution3 QuikSwap tool heads give users the ultimate flexibility. Each tool is designed for a specific purpose and can be attached or detached from the cutter in seconds

Evolution3 Fabric tool head is ideal for cutting fabric, paper, film, vinyl, banners and delicate materials. With the Evolution3 SmartFold integral polymer cutting strip there is no need for a separate cutting mat.

Evolution3 Rocker tool head is a general-purpose tool for cutting materials such as banners, cardboard and foamboard up to 10mm (3/8"). A Tech-D.012 blade can be used for the occasional cutting of aluminium composite panels, such as Dibond or Alupanel.

Evolution3 Creaser tool head will crease in both directions and is ideal for stout paper, card, cardboard, and grey board.



## Five year guarantee

Like all Keencut machines, the Evolution3 is built to give many years of excellent service. All components are manufactured in-house to ensure quality and all Evolution3 cutters come with a five year comprehensive guarantee.



## In the box

100 Graphik blades  
Double Graphik tool head (mounted)

